

# PV Grid Tie Inverter

SUN-5K-G SUN-6K-G SUN-7K-G

SUN-8K-G SUN-10K-G

## User manual



# Contents

1. Introduction	- 1 -
1.1 Appearance Introduction	- 1 -
1.2 Parts list	- 2 -
2. Safety warnings and instructions	- 3 -
2.1 Safety signs	- 3 -
2.2 Safety instructions	- 3 -
2.3 Notes for using	- 5 -
3. Operation Interface	- 6 -
3.1 Interface View	- 6 -
3.2 Status Indicator	- 6 -
3.3 Buttons	- 7 -
3.4 LCD Display	- 7 -
4. Product installation	- 8 -
4.1 Select installation location	- 8 -
4.2 Inverter Installation	- 10 -
5. Electrical Connection	- 12 -
5.1 DC input terminal connection	- 12 -
5.2 AC input terminal connection	- 15 -
5.3 The connection of the ground line	- 18 -
5.4 Inverter monitoring connection	- 18 -
6. Startup and Shutdown	- 20 -
6.1 Start up the inverter	- 21 -
6.2 Inverter Shutdown	- 21 -
7. General Operation	- 22 -
7.1 The initial interface	- 22 -
7.2 Device information	- 24 -
7.3 Fault Record	- 25 -
7.4 ON/OFF setting	- 25 -
7.5 Parameter setting	- 25 -
7.5.1 System Param	- 25 -
7.5.1.1 Time set	- 26 -
7.5.1.2 Language set	- 27 -
7.5.2 Running Param	- 27 -
7.5.3 Protect Param	- 28 -

8. Repair and Maintenance	- 29 -
9. Error information and processing	- 29 -
9.1 Error code	- 30 -
9.2 Troubleshooting	- 32 -
10. Specification	- 33 -

## Photovoltaic Grid-connected System

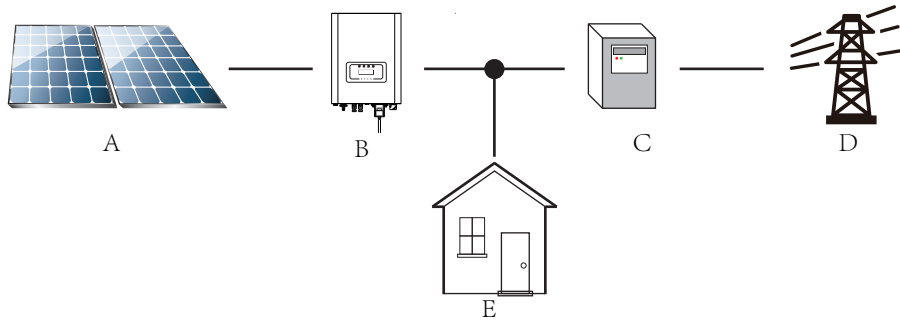

Application of inverter in photovoltaic power system

Serial number	Description
A	PV strings
B	Inverter
C	Metering device
D	Power grid
E	Family load

## 1. Introduction

### 1.1 Appearance Introduction

Three Phase String Power Inverter can convert solar panel DC power into AC power which can directly input to the grid. Its appearance is shown below. These models contain SUN-5K-G、SUN-6K-G、SUN-7K-G、SUN-8K-G and SUN-10K-G.

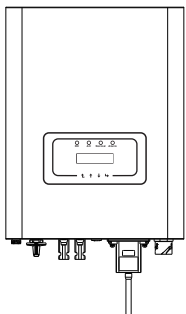

Pic1.1 Front view

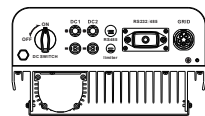

Pic1.2 Bottom view

### 1.2 Parts list

Please check the following table, to see whether all the parts are included in the package :

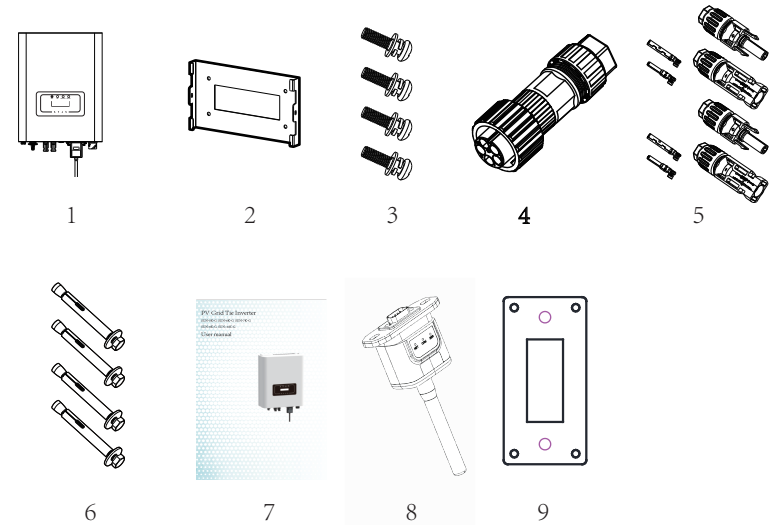

Pic1.3 Accessories drawing

No	Description	Qty
1	PV grid tie Inverter	1
2	Wall mounting bracket	1
3	Mounting stainless steel screws M4×12	4
4	AC power connectors	1
5	DC power connectors (including inserted spring)	2pairs
6	Stainless steel anti-collision bolt M6×80	4
7	User manual	1
8	Wifi-Plug (optional)	1
9	Square hole sealing plate (Wi-Fi Function selection)	1

1.1 Parts list

## 2. Safety warnings and instructions

Improper use of the inverter will cause electric shock and burn. During installation and maintenance. Please strictly follow the instructions on this manual. Please read the user manual carefully before using the inverter. And please keep the instructions properly for afterwards use.

### 2.1 Safety signs

Safety signs are used to emphasize potential safety risk and important safety information. The manual includes below signs:



#### Warning :

Safety warning——Indifference of the signs in the manual may cause injury or even death.



#### Shock Hazard :

Shock warning sign——Incorrect follow of this sign may get shocked.



#### Safety Hint :

Prudent operation——Incorrect follow of the safety operation hints in this manual may cause inverter defect.



#### High Temperature Hazard :

Inverter's local temperature may exceed 80°C while under operating. Please do not touch the inverter's surface.

### 2.2 Safety instructions



#### Warning :

Electrical installation of the inverter must conform to the safety operation rules of the country or local area.



#### Warning :

Inverter is non-isolated topology structure, hence must insure DC input and AC output are electrical isolated before operating the inverter. Strictly prohibit grounding the positive and negative poles of the PV string. Otherwise it will damage the inverter.



#### Shock Hazard :

Prohibit disassembling inverter case. There existing shock hazard, may cause serious injury or death, please ask qualified person to maintenance.



#### Shock Hazard :

When PV module is exposed to sunlight, the output will generate DC voltage. Prohibit touching to avoid shock hazard.



#### Shock Hazard :

After disconnecting the input and output of the inverter, it takes at least 5 minutes for the inverter to completely release the residual energy and waits for at least 5 minutes before it can be overhauled.



#### High Temperature Hazard :

Inverter's local temperature may exceed 80°C while under operating. Please do not touch the inverter's surface.



## 2.3 Notes for using

The three phase string power inverter is designed and tested under related safety regulations. It can ensure the personal safety of the user. But as a electric device, it may cause shock or injury by incorrect operation. Please operate the unit under below requirements:

1. Inverter should be installed and maintained by qualified person under local standard regulations.
2. It must disconnect the AC side first, then disconnect DC side before doing installation and maintenance, after disconnecting, please wait at least 5 mins to avoid getting shocked.
3. Local temperature of the inverter may exceed 80 °C while under operating. Do not touch to avoid getting injured.
4. All electrical installation must accord with local electrical standards, and after obtaining the permission of the local power supply department, the professionals can connect the inverter to the grid.
5. Please take appropriate anti-static measure.
6. Please install where children can not touch.
7. When starting the inverters, first close the circuit breaker at the grid side, then close the DC side; when closing the inverters, first disconnect the circuit breaker at the AC side, then disconnect the DC side.
8. Don't insert and remove AC and DC terminals when the inverter is in normal operation.
9. The DC input voltage of the inverter must not exceed the maximum input voltage of the model.

## 3. Operation Interface

### 3.1 Interface View

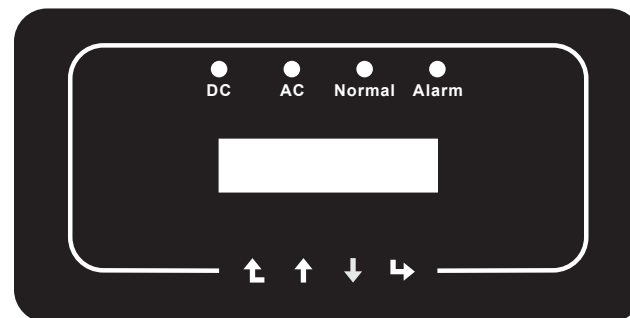

Pic 3.1 Panel

### 3.2 Status Indicator

The inverter panel has 4 indicators, the left one is DC output indicator(green), indicates normal DC input power status. Beside is the AC indicator(green), indicates normal AC connecting status. Next is the operating in dicator(green) indicates normal output. The right indicator is alarm(red), indicates alarming.

Indicator	status	Explanation
● DC	on	Inverter detects DC input
	off	Low DC input voltage
● AC	on	Grid Connected
	off	Grid Unavailable
● NORMAL	on	Under normal operating
	off	Stop operating
● ALARM	on	Detected faults or report faults
	off	Under normal operating

### 3.3 Buttons

There are four buttons on the inverter panel: above is up and increase button (UP), below is down and decrease button (DOWN), left is ESC button (ESC), right is Enter button (ENTER). The following functions can be achieved by the four buttons:

- Page turning (use UP and DOWN button)
- Modify adjustable parameters (use ESC and ENTER button)

### 3.4 LCD Display

SUN-5K-G、SUN-6K-G、SUN-7K-G、SUN-8K-G and SUN-10K-G Three-phase string inverters use a dot matrix display, mainly contains the following:

- Inverter operation status and information;
- Operating information;
- Warning message and malfunction display.

## 4. Product installation

### 4.1 Select installation location

When you receive the inverter and prepare to install it, please select a suitable location, should consider below factors:

- Ventilation—Must insure the air ventilation of the installation location, improper installation may cause overheating and effect the working efficiency and lifespan.
- Sun-shade—Expose the inverter to sunshine will cause overh eating and effect the working efficiency.
- Avoid rain and snow—Even if the inverter has IP65 protection. We still recommend installing the inverter at the ventilate place where can avoid rain and snow. It can help extend the lifespan of the inverter.



Pic4.1 Recommended installation place

- Please select the wall with certain bearing capacity.
- When doing the installation, vertical slope cannot exceed  $\pm 15^\circ$ . Make sure no lateral tilt. Otherwise it will affect the function of the heat sink. Cause the output power lower than expected.
- If install more than one inverter, must leave at least 500mm gap between each inverter. And each inverter must be at least 500mm above and below. And must install the inverter at the place where children cannot touch. Please see pic 4.3.
- Consider whether the installation environment is helpful to see the inverter LCD display and indicator status clearly.
- Must offer a ventilate environment if inverter is installed in the airtight house.



### Safety Hints :

Do not place or store any items next to the inverter.

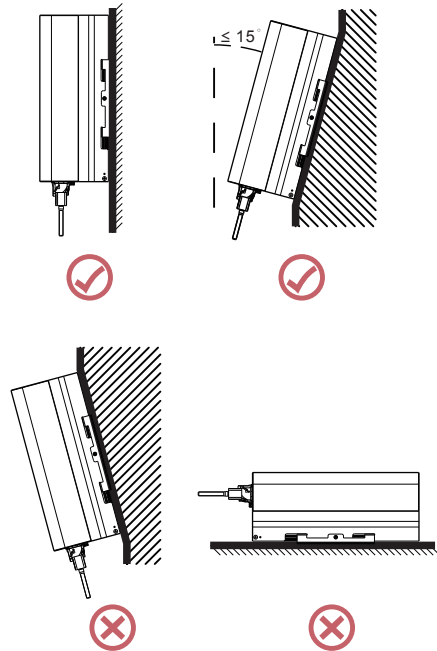

Pic4.2 Installation Angle

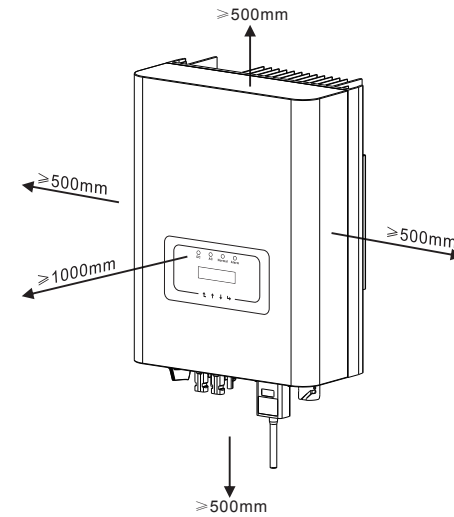

Pic4.3 Installation Gap

## 4.2 Inverter Installation

The inverter is designed according to the wall mounted type installation, please use the wall mounted (the brick wall of the expansion bolt) when installing.

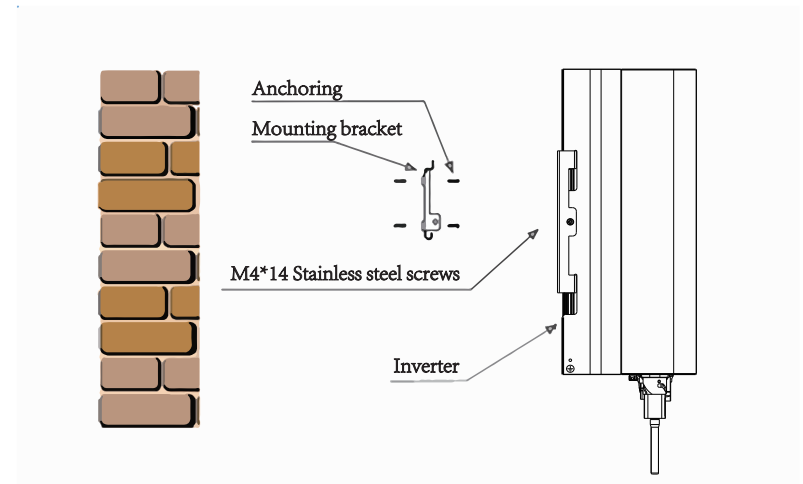

Pic4.4 Inverter Installation

Inverter should be vertically installed, as shown in pic 4.5, installation procedure shows below:

1. Position the bolts on the appropriate wall according to the bolt positions on the mounting shelves and mark the holes. On the brick wall, the installation must be suitable for the expansion bolt installation.

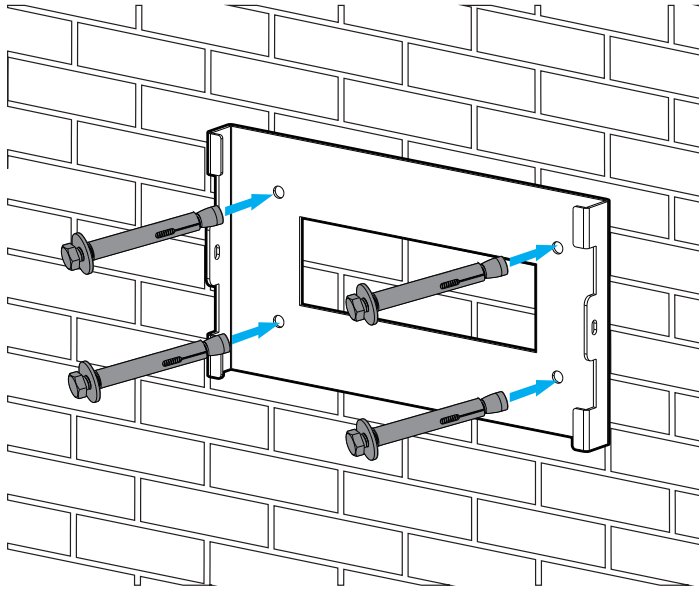

Pic4.5 Inverter hanging plate installation

2. Ensure that the position of the installation holes on the wall (A, B, C, D) are the same position of the mounting plate (picture 4.5), and the mounting level is guaranteed.

3. Hang the inverter to the top of the mounting rack and then use the M4 screw in the accessory to lock E and F (picture 4.6) to ensure that the inverter does not move.

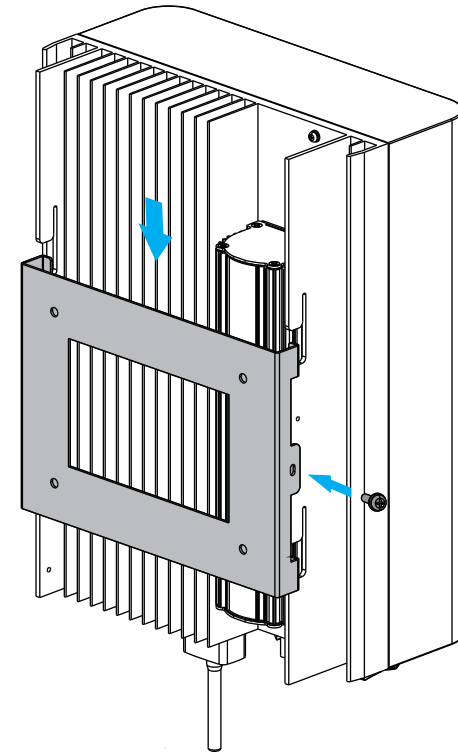

Pic4.6 Mounting of inverter

## 5 Electrical Connection

SUN-5K-G、SUN-6K-G、SUN-7K-G、SUN-8K-G and SUN-10K-G inverter has considered the convenience of the electrical connection while designing. we design fast connection for both DC and AC ,all electrical connections conform to related standards of the country .

### 5.1 DC input terminal connection

In order to safe connection, the electrical connection must follow below steps :

1. Switch AC off
2. Switch DC off
3. Connect the inverter to solar panels

a). Make sure that the polarity of the output voltage of the solar panel is consistent with the polarity identified by the inverter

b). Connect DC positive and negative to the inverter input terminal.(see picture 5.1 and picture 5.2)

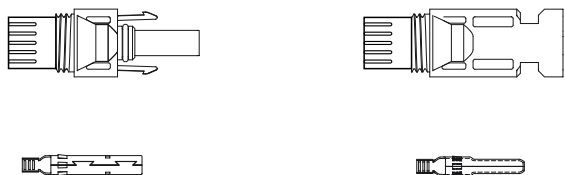

Pic 5.1 DC “+” connector (MC4)    Pic 5.2 DC “-” connector (MC4)

c).Making DC connection line Strip off the DC wire about 7mm, disassemble the connector cap nut(Picture 5.3)

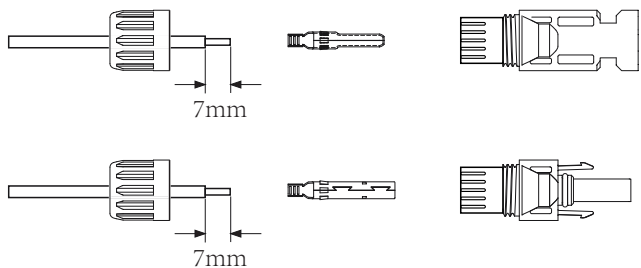

Pic 5.3 Disassemble the connector cap nut

1). Crimping metal terminals with crimping pliers as shown in Picture 5.4



Pic 5.4 Crimp the contact pin to the wire

2). Insert the contact pin into the connector housing until it locks in place. Screw the cap nut onto the connector housing. Torque to 2.5-3Nm(as shown in Picture 5.5)

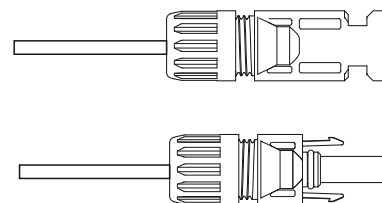

Pic 5.5 connector with cap nut screwed on

Cable type	Traverse area (mm <sup>2</sup> )		Outside diameter of cable (mm)
	Range	Recommended size	
Industry generic PV cable (model;PV1-F)	4.0-6.0 (12-10AWG)	4.0(12AWG)	5.5-9.0

Sheet 5.1 Specs of AC cable

3).Finally insert the DC connector into the positive and negative input of the inverter , shown as Picture 5.6

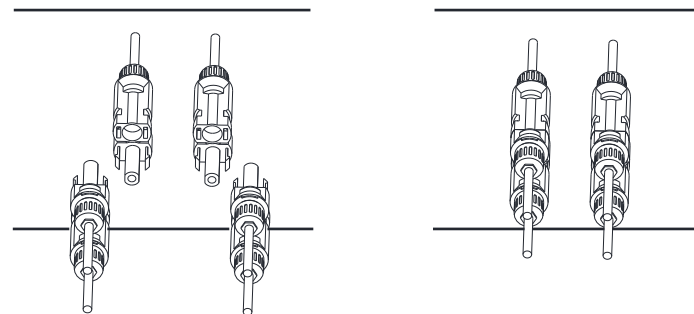

Pic 5.6 DC input connection



**NOTE:**

Sunlight shines on the panels will generate voltage, high voltage in series may cause danger to life. Therefore, before connecting the DC input line, the solar panel needs to be blocked by the opaque material and ensure that the DC switch is ‘OFF’, otherwise, the high voltage of the inverter may lead to life-threatening conditions.

**5.2 DC input terminal connection**

Do not close the DC switch after the DC terminalis connected.Connect the AC terminal to the AC size of the inverter, the AC size is equipped with Three-phase AC terminals that can be conveniently connected.Flexible cords are recommended for easyinstallation. The specifications are as shown in sheet 5.2.



**Warning :**

Prohibit using a single circuit breaker for multiple inverters , prohibit the connection of load between inverter circuit breakers.

Cable item	Dia	Cable CSA	Cable outer dia	AWG	Dia	Cable CSA	Cable outer dia	AWG
Specification	2.5mm	4mm <sup>2</sup>	15~18mm	10	2.5mm	6mm <sup>2</sup>	15~18mm	10
Model	SUN-5k/6K/7K/8K-G				SUN-10K-G			
Breaker	16A/400V				25A/400V			
Max cable length	Outside cable(3+PE)20m				Outside cable(3+PE)20m			

Sheet 5.2 Cable information

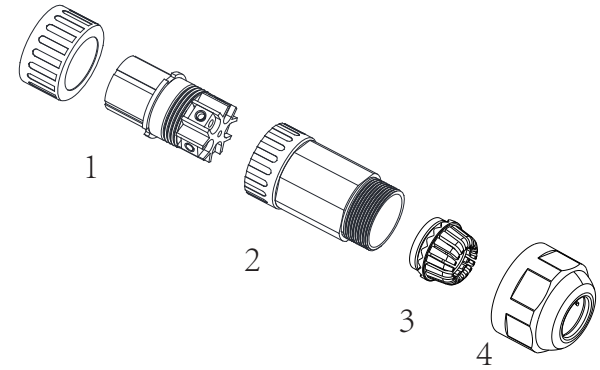

1. Matching socket 2.Sleeve 3.Sealing core 4.Sealing nut

Pic 5.7 AC connector structure

The AC output connector is divided into three parts: matching ocket, sleeve sand sealing sleeve, as shown in Picture 5.7, the steps are as fand sealing sleeve, as shown in Picture 5.7, the steps are as follows:

Step 1 Remove the cable sealing ring and sleeve in sequence from the AC connector.

Step 2 Use strippers to strip the protective sheath and insulation layer of the AC cable to the right length, as shown in Picture 5.8.

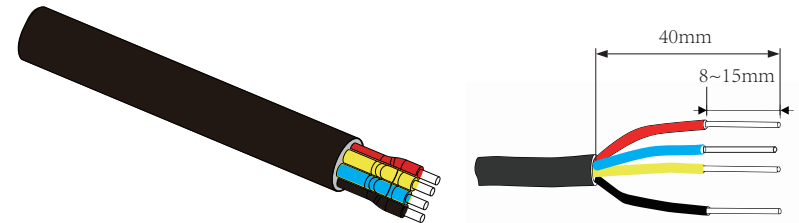

Pic 5.8 Strip AC cable



**Warning :**

Be careful to distinguish the L1, L2,L3 and PE of the AC cables.

Step 3: Insert the cable (L1, L2, L3, PE) into the sealing sleeve and sleeve.

Step 4 Use the hexagon screwdriver, loosen the bolts of the socket in turn, and insert each cable core into the corresponding jack, and set each screw. The connection hole of AC connection terminal labeling is shown in Picture 5.9.



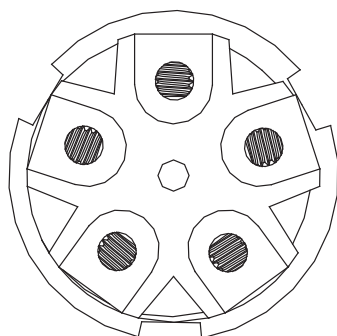

Pic 5.9 AC Connector Hole Pattern



### Safety Hint :

The AC cable line L1 is connected to socket 1; L2 is connected to socket 2; L3 is connected to socket 3, the PE line is connected to the earth , and does not involve N wire connections, please do not insert N lines into the socket of N.

Step 5 Set the sleeve and sealing ring in place

Step 6 Connect the terminals to the inverter as shown in picture 5.10.

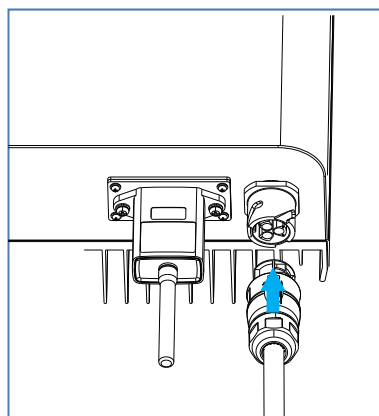

Pic 5.10 AC input connection

## 5.3 The connection of the ground line

Good grounding is good for resisting surge voltage surge and improving EMI performance. Therefore, before connecting AC, DC, and communication cables, you need to ground the cable firstly. For a single system, just ground the PE cable; For multiple machine systems, all PE cables of the inverter need to be connected to the same grounding copper platoon to ensure the equipotential connection. The installation of the shell ground wire is shown as Picture 5.11.

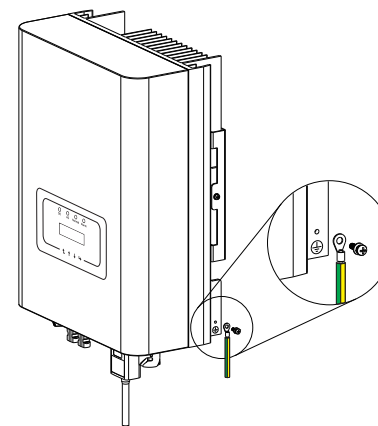

Pic 5.11 The installation of the shell ground wire



### Warning :

Inverter has built-in leakage current detection circuit, If an external leakage current protection device is connected, its operating current must be greater than 3 00 mA or higher, otherwise 1 inverter may not work properly.

## 5.4 Inverter monitoring connection

Inverter has the function of wireless remote monitoring. The inverter with Wifi function is equipped with Wifi Plug to connect the inverter and network. Wifi Plug's operation, installation, Internet access, APP downloading and other processes are detailed in the instructions. Picture 5.12 is the Internet monitoring solution.

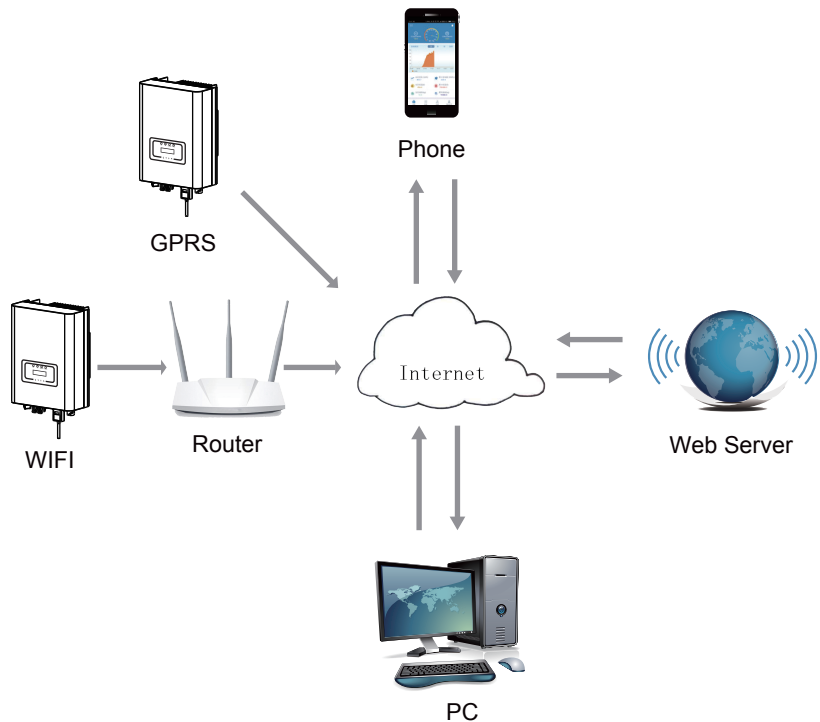

Pic 5.12 Internet monitoring solution

### 5.4.1 Installation of Wi-Fi Plug

When the inverter is out of the factory, the installation location of WiFi plug is sealed by a sealed plate as shown in Picture 5.13. When installing the Wifi Plug, remove the sealing plate, replace it with the sealing plate with square hole in the accessories, and tighten the screws. Insert the Wifi Plug into the interface and fix it with a screw. The configuration of the WiFi Plug needs to be performed after various electrical connections have been completed and the inverter DC power on. When the inverter is on the DC power, it is determined whether the WiFi Plug is normally electrified (The LED light shines out of the shell).

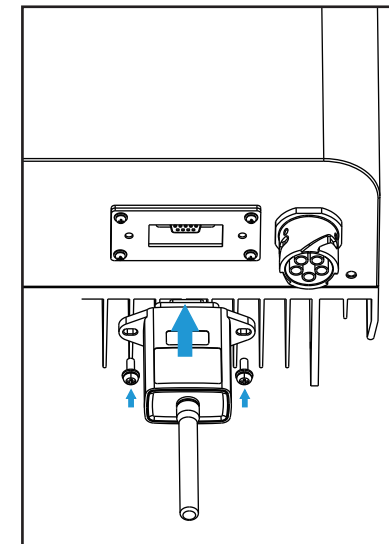

Pic 5.13 Wifi Plug installation diagram

### 5.4.2 Configuration of Wi-Fi Plug

For the configuration of Wi-Fi Plug, please refer to illustrations of the Wi-Fi Plug.

## 6. Startup and Shutdown

Before starting the inverter, make sure that the inverter can meet the following conditions, otherwise it may result in fire or damage to the inverter. In this case, we do not undertake any responsibility. At the same time, to optimize the system configuration, it is recommended that the two inputs be connected to the same number of photovoltaic modules.

- a). The maximum open voltage of each set of photovoltaic modules shall not exceed 600VDC under any conditions.
- b). Each input of the inverter must use the same type of photovoltaic module in series.
- c). Total output power of pv shall not exceed the maximum input power of inverter, each photovoltaic modules shall not exceed the rated power of each channel.
- d). The short circuit current of each series of photovoltaic modules cannot be greater than 10A at any time.

### 6.1 Start up the inverter

When start up the three phase string inverter, should follow below steps:

1. First switch on the AC breaker.
2. Turn on the DC switch of the photovoltaic module, and if the panel provides sufficient starting voltage and power, the inverter will start.
3. When the ac voltage and DC voltage are normal, the inverter start-up is ready to begin. The inverter will first check the internal parameters and the grid parameters, while the liquid crystal will show that the inverter is self-checking.
4. If the parameter is within acceptable range, the inverter will generate the normal grid. NORMAL indicator light is on.

### 6.2 Inverter Shutdown

Must follow below steps while shutting down the inverter:

1. Switch off the AC breaker.
2. Wait for 30 seconds, turn off the DC switch (if any), or simply disconnect the DC input connector. The inverter will close the LCD and all LED within two minutes.

## 7. General Operation

During normal operation, the LCD shows the current status of the inverter, including the current power, total generation, a bar chart of power operation and inverter ID, etc. Press the Up key and the Down key to see the current DC voltage, DC current, AC voltage, AC current, inverter radiator temperature, software version number and Wifi connection state of the inverter.

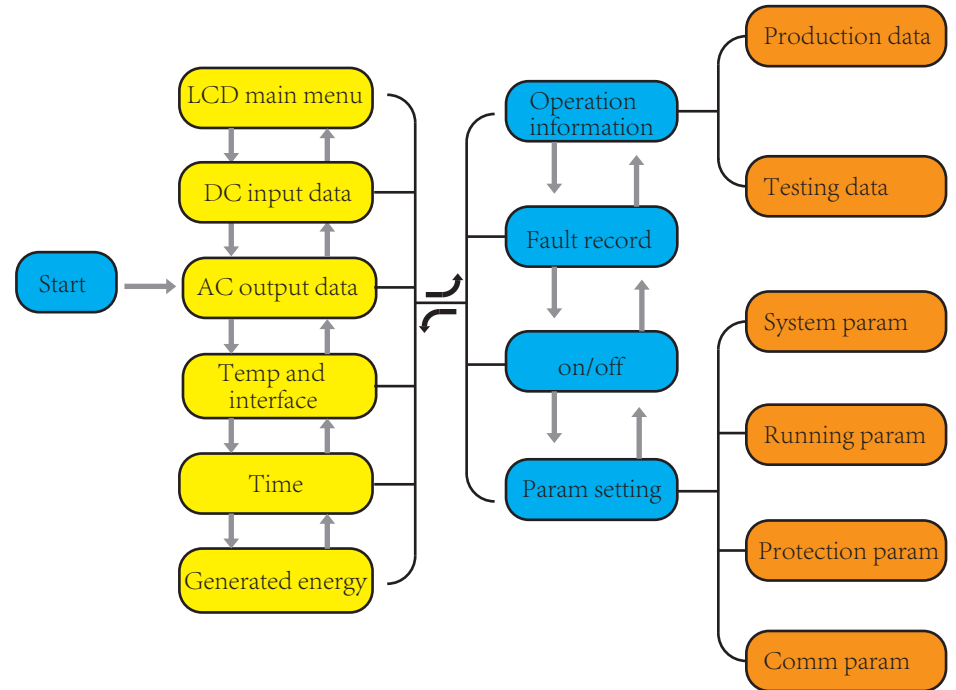

Pic7.1 LCD operation flow chart

### 7.1 The initial interface

From the initial interface, you can check power, day power, total power, inverter ID, model and time.



Pic7.2 The initial interface

Press UP or Down you can check inverter DC voltage, DC current, AC voltage, AC current, inverter temperature, software version information.



Pic7.3 PV input and DC current information

You can check the PV information, the number of strings input,MPPT voltage and MPPT current.

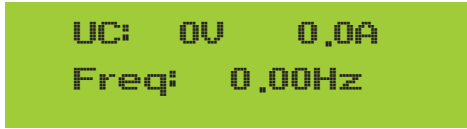

Pic7.4 AC running state information

You can check the three phase voltage, current, and grid currency.



Pic7.5 Temperature and software version

You can check the inverter inside temp, LCD software Ver137 and inverter software Ver1400. There are two black spot in the bottom right corner. The first flash means inverter is communicating with LCD. The second flash means LCD is communicating with Wifi plug. There are four submenus in the Main Menu.

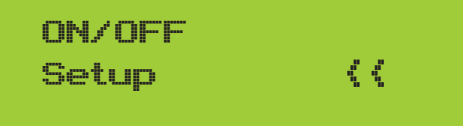

Pic7.6 Main Menu

### 7.2 Statistics information

There are five submenus in the statistics.



Pic7.7 Statistics

Into each submenu through cursor.

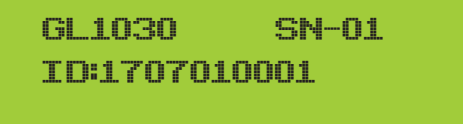

Pic7.8 E-Day

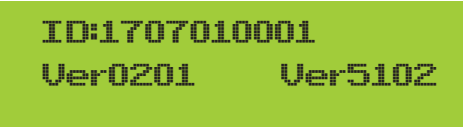

Pic7.9 E-Month

This information is for technician's reference.

### 7.3 Fault Record

Only can keep four fault record in the menu include time, customer can deal with it depends on the error code.



Pic7.10 Fault Record

### 7.4 ON/OFF setting



Pic7.11 ON/OFF setting

### 7.5 Parameter setting

Setting includes system param, run param, protect param, comm: param. All of these information for maintenance reference.

#### 7.5.1 System Param

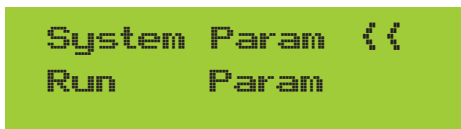

Pic7.12 Setting

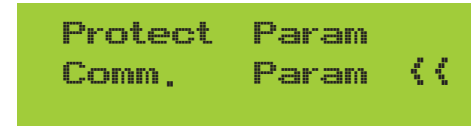

Pic7.13 Setting

System Param includes time set, language set, display set and factory reset.

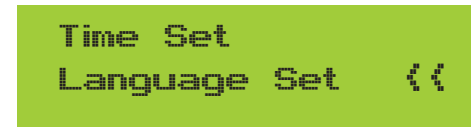

Pic7.14 System Param

#### 7.5.1.1 Time set



Pic7.15 Time set

### 7.5.1.2 Language set

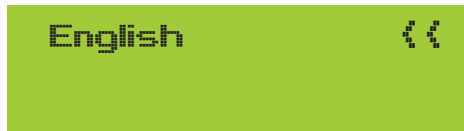

Pic7.16 Language set

### 7.5.2 Running Param



#### Note :

Password required-restricted access-authorized engineer only.Un-authorized access may avoid the warranty. The initial password is 1234.



Pic7.17 Password



Pic7.18 Running Param

### 7.5.3 Protect Param



#### Note :

Engineer Only.

We will set the param depends on the safety requirements, so customers don't need to reset it. The password is same as 7.5.2 Running param.



Pic7.19 Protect Param



#### Note :

Engineer only.

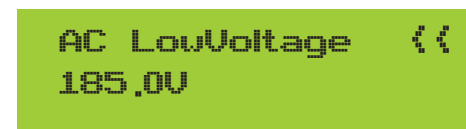
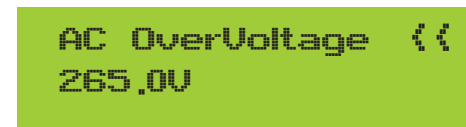



AC OverFreq <<  
51.50Hz

AC LowFreq <<  
47.50Hz

Pic7.20 “CUSTOM”

## 8. Repair and Maintenance

String type inverter doesn't need regular maintenance. However, debris or dust will affect heat sink's thermal performance. It is better to clean it with a soft brush. If the surface is too dirty and affect the reading of LCD and LED lamp, you can use wet cloth to clean it up.



### Warning:

When the device is running, the local temperature is too high and the touch can cause burns. Turn off the inverter and wait for it cooling, then you can clean and maintain.



### Warning:

When cleaning any part of the inverter, no solvent, abrasive materials or corrosive materials shall be used for cleaning.

## 9. Error information and processing

Three-phase string inverters are designed according to grid-connected operating standards. It meets safety requirements and electromagnetic compatibility

requirements. Before leaving the factory, the inverter has undergone several rigorous tests to ensure that it can be operated reliably and permanently.

### 9.1 Error code

In the case of failure the LCD screen will display an alarm message. In this case the inverter may stop feeding energy into the grid. The alarm description and their corresponding alarm messages are listed Table 9.1.

Error code	Description
F01	DC input polarity reverse fault
F02	DC insulation impedance permanent fault
F03	DC leakage current fault
F04	Ground fault GFDI (battery and grounding)
F05	Read the memory error
F06	Write the memory error
F07	GFDI blown fuse
F08	GFDI grounding touch failure
F09	IGBT damaged by excessive drop voltage
F10	Auxiliary switch power supply failure
F11	Ac main contactor errors
F12	AC auxiliary contactor errors
F13	Reserved
F14	DC firmware over current
F15	AC firmware over current
F16	GFCI(RCD) Ac leakage current fault
F17	Three phase current, over-current fault
F18	AC over current fault of hardware
F19	All hardware failure synthesis
F20	DC over current fault of the hardware
F21	DC leakage flow fault
F22	Crash stop (if there is a stop button)
F23	AC leakage current is transient over current
F24	DC insulation impedance failure
F25	DC reverse irrigation failure
F26	The DC busbar is unbalanced
F27	DC end insulation error

F28	Inverter 1 DC high fault
F29	AC load switch failure
F30	AC main contactor failure
F31	AC secondary contactor failure
F32	Inverter 2 dc high fault
F33	AC over current
F34	AC current over load
F35	No AC grid
F36	AC grid phase error
F37	AC three-phase voltage imbalance failure
F38	AC three-phase current imbalance failure
F39	AC over current
F40	DC over current
F41	AC Line W,U over voltage
F42	AC Line W,U low voltage
F43	AC Line V,W over voltage
F44	AC Line V,W low voltage
F45	AC Line U,V over voltage
F46	AC Line U,V low voltage
F47	AC Over frequency
F48	AC lower frequency
F49	U phase grid current DC over current
F50	V phase grid current DC over current
F51	W phase grid current DC over current
F52	AC inductor A, phase current DC current high
F53	AC inductor B, phase current DC current high
F54	AC inductor C, phase current DC current high
F55	DC busbar voltage is too high
F56	DC busbar voltage is too low
F57	AC reverse irrigation
F58	AC grid U over current
F59	AC grid V over current
F60	AC grid W over current
F61	Reactor A phase over current
F62	Reactor B phase over current

F63	Reactor C phase over current
F64	IGBT heat sink high temperature

Table9.1 Error code

## 9.2 Troubleshooting

F41~F48	Grid voltage exceed the nomal working range
F35	Grid Failure
F55 F56	Solar over voltage or low voltage
F26	Loss one phase or poor connection or inverter hardware damage
F15 F18	Grid have some surge load
F23	Ground error or PV + or - short to the Ground
F24	PV+ or PV- to the Ground resistance too low .

Table9.2 Troubleshooting



### Note :

If your SUN-5K/6K/7K/8K/10K-G string inverter has any of the fault information shown in Table 9.1, and when you reset the machine and still don't solve the problem, please contact our distributor and provide the below details:

1. Serial number of the inverter;
2. The distributor/dealer of the inverter (if available);
3. Grid generation date;
4. The description of problem (include LCD's error code and LED status indicator lights);
5. Your contact details.

## 10.Specification

Model	SUN-5K-G	SUN-6K-G	SUN-7K-G	SUN-8K-G	SUN-10K-G
Energy source	Grid-connected PV				
<b>Input Side</b>					
Max.DC Power(kW)	6.5	7.8	9.1	10.4	12
Max.DC Input Voltage(V)	900				
Start-up DC Input Voltage(V)	250				
MPPT Operating Range(V)	200~800				
Max.DC Input Current(A)	10+10				
Number of MPPT/ Strings per MPPT	2/1				
<b>Output Side</b>					
Rated Output Power(kW)	5	6	7	8	10
Max.Active Power(kW)	5.5	6.6	7.7	8.8	11
Rated AC Grid Voltage(V)	380/400				
AC Grid Voltage Range(V)	277~460				
Rated Grid Frequency(Hz)	50/60(Optional)				
Operating Phase	Three phase				
Rated AC Grid Output Current(A)	7.2	8.7	10.1	11.6	14.5
Max.AC Output Current(A)	8	9.57	11.11	12.76	16
Output Power Factor	>0.99				
Grid Current THD	<3%				
DC Injection Current(mA)	<0.5%				
Grid Frequency Range	47-52 or 57-62 (optional)				
<b>Efficiency</b>					
Max.Efficiency	98.3%				
Euro Efficiency	97.5%				
MPPT Efficiency	>99%				
Protection	DC reverse-polarity protection; AC short circuit protection; AC output overcurrent protection;Output over-voltage protection;Insulation resistance protection;Ground fault monitoring;Surge protection;Islanding protection; Temperature protection; Integrated DC Switch (Optional);				

<b>General Data</b>	
Size(mm)	385W×479H×184D
Weight(kg)	15
Topology	Transformerless
Internal consumption	<1W(Night)
Operating temperature	-25 ~ 60 ℃
Ingress protection	IP65
Noise Emission(Typical)	<30dB
Cooling Concept	Intelligent cooling
Max.Operating Altitude Without Derating	2000m
Designed Lifetime	>20Years
Grid Connection Standard	EN50438;IEC61727;VDE4105;NB/T32004(CQC);IEC62109-1-2
Operation surrounding humidity	0~100%
Stafty EMC / Standard	IEC62109-1/-2,EN61000-6-1,EN61000-6-3
<b>Features</b>	
DC Connection	MC-4 mateable
AC Connection	IP65 rated plug
Display	LCD1602
Interface	RS485/RS232

Table10.1 Specification